

**WRIST GAMMA INDICATOR
PM 1208**

OPERATING MANUAL

JV POLIMASTER Ltd.

Minsk 2001

This Operating Manual describes the design, operation and use of the wrist gamma indicator PM 1208 (hereinafter referred to as indicator). The Operating Manual includes the general description of the indicator, specifications, instructions for its maintenance, as well as some other information necessary for a proper operation of the indicator and a full realization of its possibilities.

During manufacturing of the wrist gamma indicator PM 1208 some changes may be introduced in its electrical scheme and construction, that do not influence the specifications and, therefore, may be not specified in this manual.

CONTENTS

	Page
1 DESCRIPTION AND OPERATION OF THE INDICATOR	4
1.1 Application of the indicator.....	4
1.2 Delivery kit	5
1.3 Specifications	6
1.4 Design and theory of operation	10
2 USE OF THE INDICATOR	11
2.1 General information	11
2.2 Safety instructions	12
2.3 Preparation for use	12
2.4 Modes of operation	13
2.4.1 Operation of the indicator in the indication mode	14
2.4.2 Operation of the indicator in the audible dose rate indication mode.....	14
2.4.3 Operation of the indicator in the reference mode	15
2.4.4 Operation of the indicator in the set mode	17
2.4.5 Operation of the indicator in the mode of digital adjustment of electronic watch accuracy	20
2.4.6 Mode of indication of partial and critical battery discharge	21
2.4.7 The movement of the electronic quartz watch	21
3 MAINTENANCE	22
4 TROUBLESHOOTING	24
5 STORAGE AND SHIPPING	25
6 WARRANTY	26
7 PACKING CERTIFICATE	27
8 ACCEPTANCE CERTIFICATE	28
9 WARRANTY CERTIFICATE	29

1. DESCRIPTION AND OPERATION OF THE INDICATOR

1.1 Application of the indicator

The indicator is designed for:

- continuous all day registration and indication of the ambient dose equivalent rate of gamma radiation $\dot{H}^*(10)$ (hereinafter referred to as DER) in the digital and analogue (on the linear graphic scale of the DER control) forms;
- continuous all day registration and indication of the ambient dose equivalent of gamma radiation $H^*(10)$ (hereinafter referred to as DE) in the digital and analogue (on a circular graphic scale of the DE control) forms;
- audio alarming when the preset DER or DE thresholds are exceeded;
- indication of the ambient dose equivalent accumulation time;
- indication of the time in hours, minutes and seconds, date and the number of month on the digital liquid crystal display;
- use as an alarmclock;
- indication of the time in hours, minutes and seconds on the electronic analogue quartz watch (thereafter referred to as quartz watch).

The indicator may be used to assess the radiation situation and to provide audible alarms in the case of radiation danger (when the threshold values are exceeded), to detect the radioactive contamination sites or to locate the gamma radiation sources, to assess the ambient dose equivalent and its accumulation time, and also as a wrist watch.

The indicator readings may not be used for official findings.

For proper interpretation of the results obtained using an indicator it is recommended to take advice of local competent institutions.

Operation conditions:

- temperature range: from 0 to +45 °C;
- relative humidity: up to 95% at + 45 °C.

1.2 Delivery kit

1.2.1 The delivery kit of the indicator is given in Table 1.1.

Table 1.1

Item	Type	Quantity	Note
Wrist gamma indicator PM 1208	100345122.029.2001	1	
Band		1	The indicator may be supplied without band, on request, or the band type may be stated in the contract
Operating manual	412118.028	1	
Battery for the electronic registration block	CR2032	1	Batteries are inserted into the indicator, or , on request, batteries may be not inserted
Battery for the electronic quartz watch	SR 621 SW	1	
Case	412915.025	1	Another case that meets the requirements of the Technical Conditions may be used to suit customer's requirements and conditions of delivery

1.3 SPECIFICATIONS

1.3.1 The indicator performs registration and indication of the DER value in the range from 0.01 to 4000 $\mu\text{Sv/h}$ on the liquid crystal display (LCD) in the digital and analogue (on the linear graphic scale) forms.

The error of the DER registration in the range from 0.1 to 4000 $\mu\text{Sv/h}$ is no more than $\pm 30\%$.

1.3.2 The indicator performs registration and may indicate the DE value in the range from 0.001 to 9999 mSv on the LCD in the digital and analogue (on the circular graphic scale) forms.

The upper limit of the DE registration is dependent on the DER value and a capacity of the battery used.

The error of the DE registration in the range from 0.001 to 9999 mSv is no more than $\pm 25\%$.

Note. The DE value is reset, when the battery is removed.

1.3.3 The indicator provides setting and storage in the memory the DER and DE threshold values.

The steps of thresholds are as follows:

- for DER: 0.01;0.1;1.0;10.0;100 $\mu\text{Sv/h}$;
- for DE: 0.001;0.01;0.1;1.0;10.0;100 mSv.

The indicator performs continuous control of the registered DER and DE values relative to the preset thresholds and represents these relative values on the analogue graphic scales.

The least division (two segments) of the analogue linear scale of the DER control is one tenth of the preset DER value. The least division (two segments) of the analogue circular scale of the DE control is one tenth of the preset DE value.

When the registered DER value is equal to or higher than the preset DER value, the linear analogue scale is completely filled in, an audible signal sounds, and the LCD indicates the DER value. To stop this signal, press and release the button 1 ("set") or button 2 ("mode") (see Fig. 1.2). The indicator continues the registration and indication of DER.

When the registered DE value is equal to or higher than the preset DE value, the circular analogue scale is completely filled in, an audible signal sounds, and the LCD indicates the DE value. To stop this signal, press and release the button 1 ("set") or button 2 ("mode"). The indicator continues the registration and indication of DE.

1.3.4 The indicator shows the DE accumulation time in hours with a step of 1 hour.

1.3.5 The indicator provides registration of gamma radiation in the energy range from 0,06 to 1,5 MeV.

1.3.6 The power for the operation of the electronic registration block is provided by a battery of the CR 2032 type (210 mAh) with voltage of 3 V.

There are two levels of the electronic registration block battery discharge warning:

the 1st level: indication of partial battery discharge: the linear analogue scale flashes every second and audible signals do not sound.

the 2nd level: indication of critical battery discharge: registration is interrupted, the indicator does not respond to the controls and displays the DE value.

The power for operation of the movement of the electronic quartz watch is provided by a battery of the SR 621 SW type (20.5 mAh) with voltage of 1.5 V.

1.3.7 The time of reading stabilization is no more than 360 s, when the natural radiation background (0,1-0,2) $\mu\text{Sv/h}$ is registered after the influence of radiation with DER value over 1 $\mu\text{Sv/h}$, or the processor operation was restarted. The time of reading stabilization decreases with increasing the registered DER value.

1.3.8 The indicator provides operation in the search mode, i.e. when the gamma radiation is detected, it sounds audible signals, which rate increases with increasing the DER value.

1.3.9 Deviations of the average values of the indicator readings of DER and DE as against those recorded under normal conditions are no more than:

- $\pm 15\%$ due to temperature variations from normal to high or low;
- $\pm 15\%$ due to humidity variations from normal to high;
- $\pm 15\%$ at limiting values of power voltage.

1.3.10 The indicator provides setting and adjustment of the current time in hours (from 0 to 24) and minutes (from 0 to 60); minutes (from 0 to 60) and seconds (from 0 to 60), as well as the date (from 1 to 31) and month (from 1 to 12).

1.3.11 The indicator provides the digital adjustment of the electronic watch accuracy. The accuracy of the digital watch is ± 1 s/24 hours when the digital adjustment of the electronic watch accuracy is used.

The movement of the quartz watch provides its accuracy at normal conditions of ± 1 s/24 hours.

1.3.12 The indicator may be used as an alarmclock with an audible signal sounded during one minute at the set time with a period of 24 hours.

1.3.13 The battery (CR2032, 210 mAh) lifetime is at least 1 year provided that the following operating conditions are observed:

- average registered DER value is no more than 0,2 $\mu\text{Sv/h}$;
- backlight is used for no longer than 3 s/24 hours;
- audible signals sound for no longer than 20 s/24 hours.

The electronic quartz watch operates at least 36 months with a battery SR 621 SW (20.5 mAh).

1.3.14 The indicator is supplied with a display backlight, which is turned ON when the button 3 (LIGHT) is pressed (see Fig. 1.2).

1.3.15 The case of the indicator protects it from

- dust;
- water penetration when the indicator in static position its front panel upwards is immersed in water to a depth of 100 m for a short-time period. (Degree of protection IP 68).

1.3.16 The indicator is resistant to:

- air temperatures from 0 °C to 45 °C;
- relative air humidity up to 95% at 40 °C.

1.3.17 The indicator is resistant to shocks with an acceleration of 100 m/s^2 , a shock pulse duration from 2 to 50 ms, and a rate from 60 to 180 shocks per minute.

1.3.18 The indicator is resistant to sinusoidal vibrations with a frequency of 10-55 Hz and a shift amplitude for frequencies below the transition frequency of 0,35 mm.

1.3.19 The indicator in a case for transportation is resistant to:

- air temperatures from -50°C to $+50^{\circ}\text{C}$;
- air humidity up to 100% at 40°C ;
- shocks with an acceleration of 98 m/s^2 and duration of 16 ms;
- sinusoidal vibrations with a frequency of 10-55 Hz, shift amplitude for frequencies below the transition frequency of 0,35 mm.

1.3.20 The overall dimensions of the indicator (without band) are no more than 50x45x20 mm.

The weight of the indicator (without band) is no more than 0,1 kg.

1.3.21 Reliability parameters of the indicator are as follows:

- average full operating time: no less than 20000 h;
- average service life: no less than 8 years;
- average time of recovery: no more than 60 min.

Note. The methods of checking the technical parameters or some additional information are available on request or may be found at the address: www.polimaster.com.

1.4 Design and theory of operation

1.4.1 The indicator is designed as a wrist watch and includes an electronic block of registration and a movement of electronic quartz watch, each powered separately.

The microprocessor controls over the modes of operation of the indicator (except for the electronic quartz watch movement), digital watch, processing, storage and indication of information, and self testing.

The device uses a Geiger-Muller tube with an energy compensating filter as a radiation detector, which converts the gamma radiation quanta to electric pulses.

An algorithm of the indicator work provides a continuous registration of gamma radiation, the necessary statistical processing of the results received and their adequate indication on the LCD, a fast adaptation to variations of the radiation levels, setting of the response time in inverse dependence on the dose rate.

The indicator is supplied with an electroluminescent backlight.

1.4.2 The general view of the indicator is given in Fig 1.2.

The LCD is located on the front panel of the indicator. The hands of the electronic quartz watch are located above the LCD. Four buttons to control the electronic block of registration and a crown to control the movement of the electronic quartz watch are located around the periphery of the device case.

The button 4 “**reset**” used to restart the microprocessor operation is flush-mounted to avoid its accidental pressing.

A direction of graduation and an effective center of the detector, relative to which the factory calibration is performed are shown in Fig. 1.2.

The total surface density of the indicator frontal and side walls enclosing the detector is 1 g/cm^2 . This provides the detector protection from the background beta radiation. The same protection from the back side is provided by the human hand.

The controls and elements of indication are as follows:

1 - the “**mode**” button is used to switch between the indicated values:

- DER indication,
- DE indication,
- current time indication,

as well as to change the parameters, to switch the alarmclock ON/OFF, to turn ON/OFF the dose rate audible indication (see.Fig. 1.2);

2 - the “**set**” button is used to enter the *reference mode* and to exit from it, to enter the *set mode* and to exit from it;

3 – the “**light**” button is used to switch the backlight ON;

4 – the “**reset**” button is used to restart the microprocessor operation;

5 - digital panel of the LCD;

6 - segments of the circular analogue scale of DE values;

7 - circular analogue scale of DE values;

8 – segments of the linear analogue scale of DER values;

9 - linear analogue scale of DER values;

10 – the “ γ ” sign showing that the indicator is displaying the parameters of gamma radiation;

11 - "Current Time mode" sign (“clock” sign);

12 - "Alarmclock ON" sign indicating that the alarmclock will sound at the preset time;

13 – “ $\mu\text{Sv/h}$ ” sign indicating that the DER (in $\mu\text{Sv/h}$) is displaying;

14 - “mSv” sign indicating that the DE (in mSv) is displaying;

15 - "Sound indication ON" sign indicating that the dose rate audible indication is set ON;

16 - "Set mode" sign;

17 - dividing sign “:” (colon);

18 - dividing sign “.” (point);

19- crown to control the movement of the electronic quartz watch.

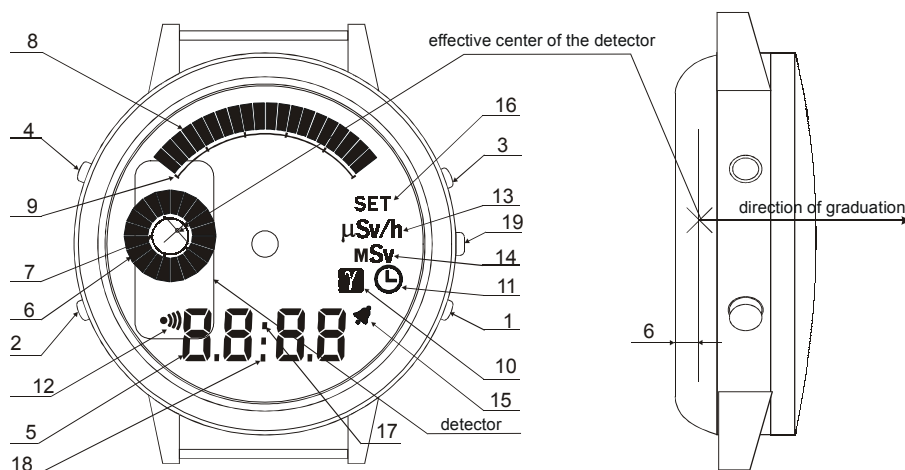

Fig.1 2.

2 USE OF THE INDICATOR

2.1 General information

2.1.1 Modes of operation of the indicator are listed below.

The operation modes of the electronic block of registration:

- the self-testing mode;
- the indication mode with selection of an indicated value: DER, DE, Current Time;
- the audible DER indication mode (the mode of searching gamma radiation sources);
- the reference mode;
- the set mode;
- the alarmclock mode;
- the mode of digital adjustment of the electronic watch accuracy;
- the mode of indication of partial and critical battery discharge.

The operation modes of the electronic quartz watch:

- the mode of indication of the current time (in hours, minutes, seconds);
- the mode of setting the current time.

While in any mode (except for the self-testing and the mode of indication of critical battery discharge) the indicator performs continuous registration of DER and DE and counts the time of DE accumulation.

Press the button 3 “**light**” (Fig.1.2) to switch ON the LCD electroluminescent backlight. The short pressing of the button will switch the backlight ON for approximately 1 second. The long pressing (pressing and holding the button) will switch the backlight ON for the time of the button holding.

2.2 Safety instructions

2.2.1 During the indicator adjustment, checking, repair and maintenance, if radioactive sources are used, the regulations for work with radioactive materials and other radiation sources, as well as Standards of radiation safety should be followed.

2.2.2 When the indicator is to be used within a territory presumably contaminated by radioactive materials, it is necessary to use the means of personal protection and to minimize the time of staying within this territory to eliminate the possibility of contamination by radioactive materials.

2.3 Preparation for use

2.3.1 Before using the indicator it is necessary to study the present manual.

2.3.2 The indicator may be supplied with the inserted batteries, as well as with batteries supplied separately in the same delivery kit. In the first case, the indicator is ready to operation after it is taken out from the case. In the second case, it is necessary to insert the batteries as described in the section 3.3.

Note. If the indicator is to be used under conditions when the DER value is presumably higher than 100 $\mu\text{Sv/h}$, it is recommended to insert new batteries.

2.3.3 The controls of the indicator may be used in two ways:

- pressing (for approx. 1 second) and releasing, hereinafter referred to as “short pressing”;
- pressing and holding (for approx. 2 seconds), hereinafter referred to as “long pressing”;

2.4 Modes of operation of the indicator

2.4.1 Operation in the indication mode

The electronic registration block of the indicator operates continuously in this mode, performs the gamma radiation registration, calculation of DER, DE values and indicates the current time.

The selection of the indicated value is performed by short press of the “mode” button 1. Each repeated press of this button will cause the indication of the values in the following rotation: Current Time - DER - DE - then again Current Time, etc. (see Fig. 2.1); the corresponding signs appear on the display.

- DER, $\mu\text{Sv/h}$, “ $\mu\text{Sv/h}$ ” sign, “ γ ” sign
- DE, mSv, “mSv” sign, “ γ ” sign;
- Current Time,  “clock” sign.

The relative DE and DER values are indicated in the analogue format on the corresponding analogue scales that appear on the display if the DE or DER values exceed 0.1 of the preset thresholds. The closeness of the DE and DER current values to their thresholds can be judged from the degree of these scales filling in. When the DE and DER values exceed the thresholds,

the corresponding scales will be completely filled in and an audible signal will sound.

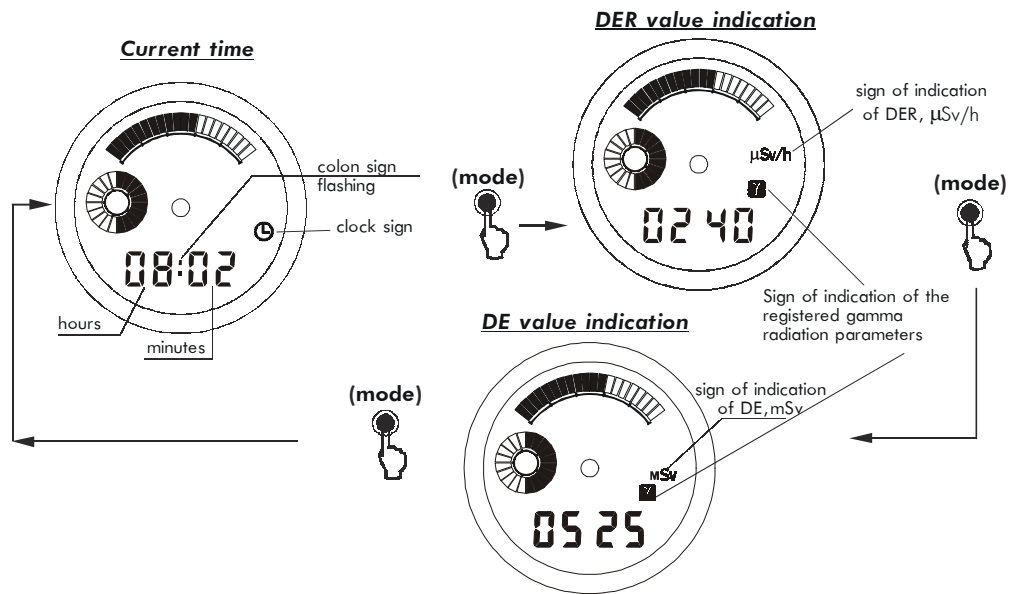

Fig. 2.1

2.4.2 Operation in the mode of the dose rate audible indication

Press and fix the “**mode**” button 1 in any of the above mode to set the **dose rate audible indication ON**; the next value in a rotation described in the clause 2.4.1 and the corresponding sign will be displayed (Fig. 2.2).

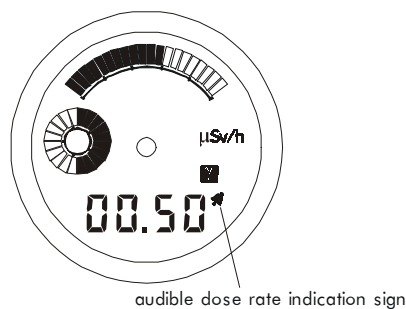

Fig. 2.2

At the natural background, the rate at which audible signals repeat is a few signals per minute. It will increase with increasing the gamma-radiation

intensity as a result of, e. g. approaching to a radiation source. **This provides a possibility of searching and locating rather intense gamma-radiation sources.**

2.4.3 Operation in the reference mode

The next information may be displayed on the LCD while in the reference mode:

- the time (hours and minutes) when the alarmclock will be turned ON;
- date and the month's number;
- the current time (minutes and seconds);
- the preset thresholds of DER ($\mu\text{Sv/h}$) and DE (mSv);
- the time of DE accumulation (in hours).

While in this mode the alarmclock may be also turned ON/OFF

Switching from the time indication to the reference mode.

Enter the Current Time mode as described in the clause 2.4.1. Press and release the “set” button 2 to see on the LCD in rotation the information as follows (Fig. 2.3):

- the time (hours and minutes) when the alarmclock will be turned ON;
- date and the month's number;
- the current time (minutes and seconds).

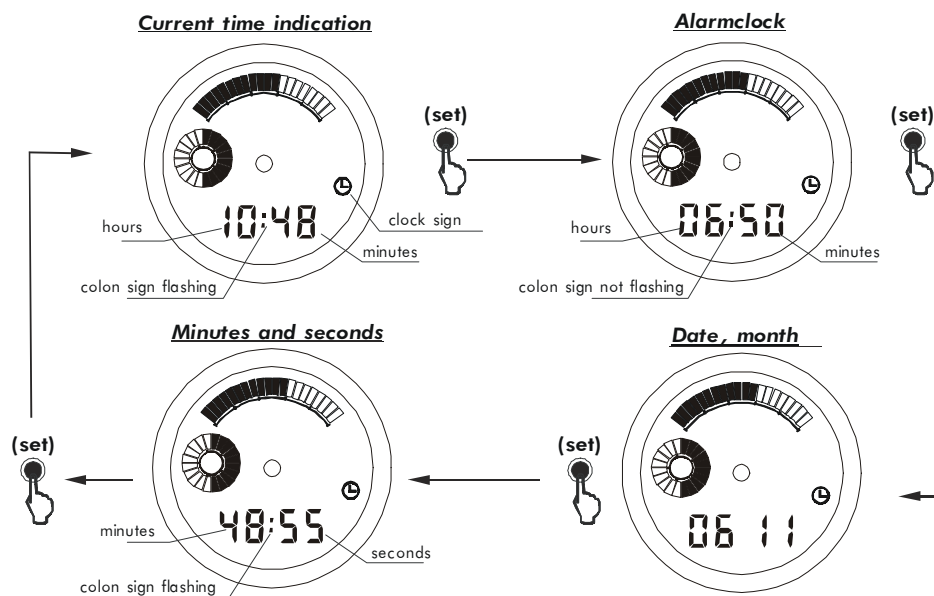

Fig. 2.3

The display will automatically return to the Current Time mode, if the buttons are left unused for approximately 5 seconds.

Exception: to exit from the indication of minutes and seconds it is necessary to press and release the “set” button 2 again.

To set the alarmclock ON (OFF), press and release the “mode” button when the alarmclock ON time is displayed; the corresponding sign will be indicated (Fig. 2.4).

The alarmclock signal will sound at the preset time. Press and release the “mode” or “set” button to stop the sound signal. If the buttons are left unused, a signal will sound for 60 seconds.

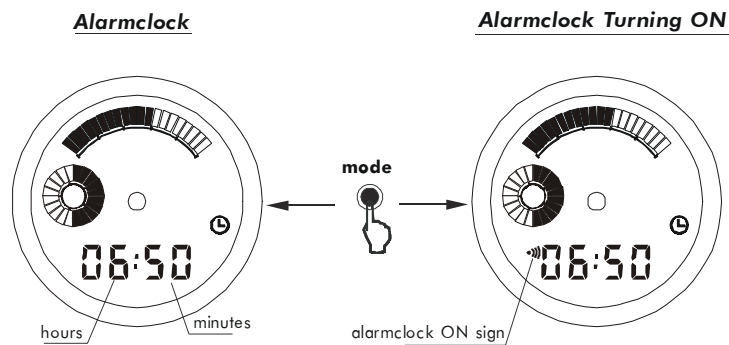

Fig. 2.4

Switching from the DER indication to the reference mode.

Enter the DER indication as described in the clause 2.4.1. Then press and release the “set” button 2 to display the preset threshold of DER ($\mu\text{Sv/h}$) and the filled in linear analogue scale on the LCD (Fig. 2.5). In approximately 5 seconds the indicator will automatically return to the DER indication.

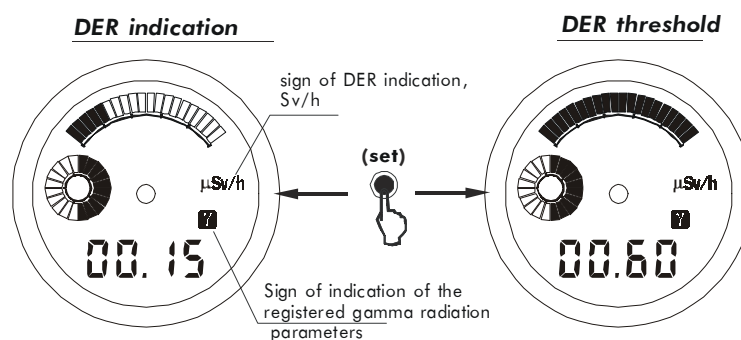

Fig. 2.5

Switching from the DE indication to the reference mode.

Enter the DE indication as described in the clause 2.4.1. Then press and release the “set” button 2 to see on the LCD in rotation the information as follows (Fig. 2.6):

- the preset DE threshold (mSv) and the filled in circular analogue scale;
- the time of DE accumulation (hours).

In approximately 5 seconds the LCD will automatically return to the DER indication.

Knowledge of the DE accumulation time is of great importance from the point of view of medical and biological consequences for a human organism !

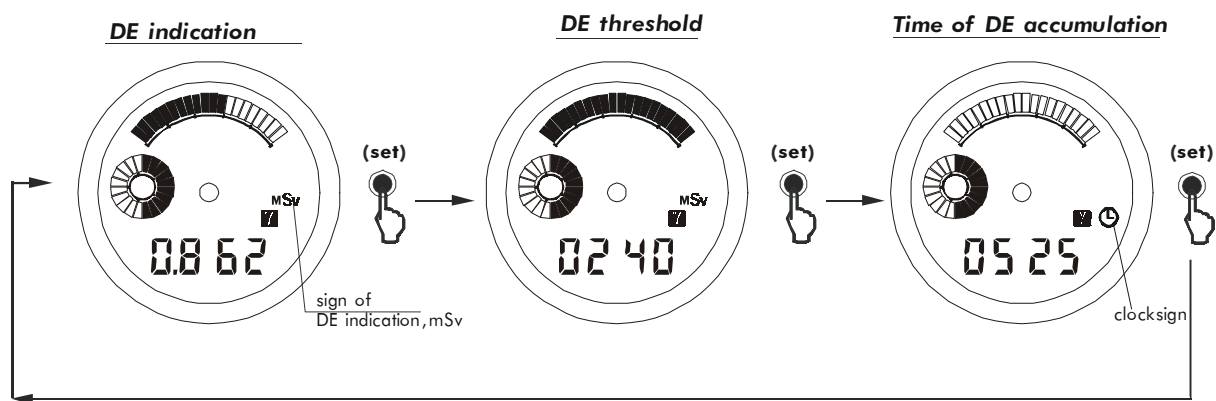

Fig. 2.6

2.4.4 Operation in the set mode

Setting the alarmclock ON time and the current time

Enter the time indication as described in the clause 2.4.1. Then press and fix the “set” button 2, the display will show the set mode sign and hours flashing (Fig. 2.7).

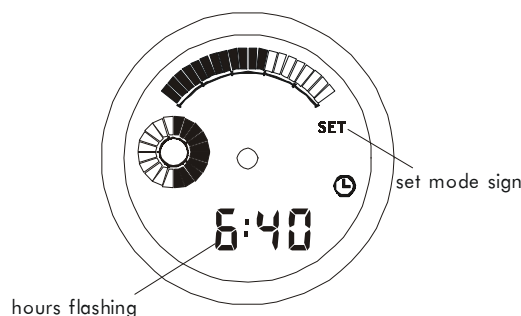

Fig. 2.7

Press and release the “**mode**” button 1 to correct the flashing digit, each press will increase the number by one. The LCD will display the alarmclock turning ON sign 12 (see Fig. 1.2). This means that after setting the alarmclock ON time, the alarmclock will be turned ON.

To turn the alarmclock OFF it is necessary to enter the reference mode and perform the procedures described in the clause 2.4.3.

For setting the minutes, press and release the “**set**” button 2 again. The minutes will be flashing. Each press of the “**mode**” button 1 will increase the number by one.

So, each short press of the “**set**” button will switch between the values in rotation shown on Fig. 2.8:

- hours of setting the alarmclock ON time;
- minutes of setting the alarmclock ON time;
- seconds of the current time;
- minutes of the current time;
- hours of the current time;
- date;
- month’s number

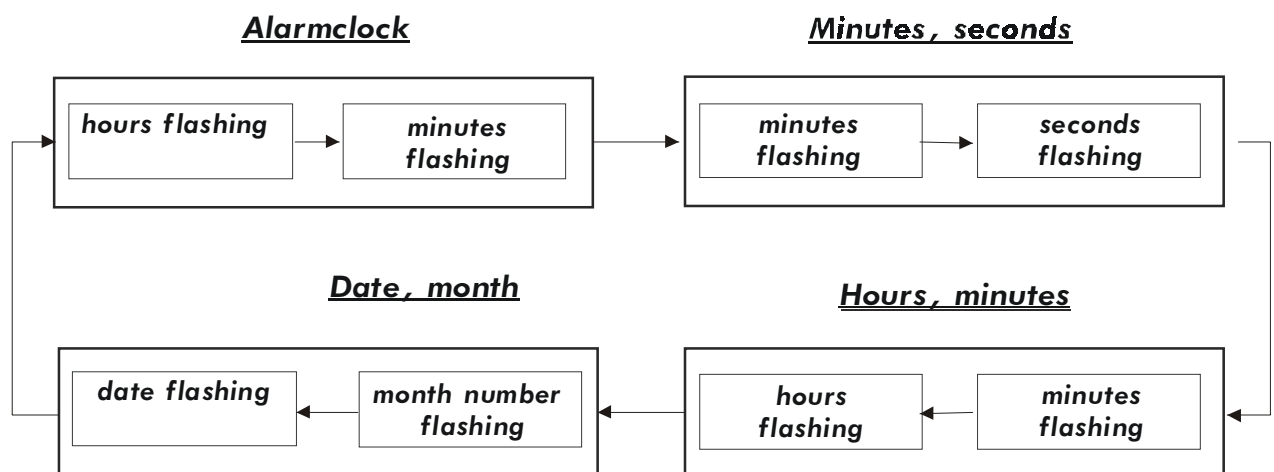

Fig. 2.8

To correct the flashing digit press and release the “**mode**” button 1. Hold this button down to change the numbers rapidly.

Exception: the “**mode**” button pressing when seconds of the current time are flashing will result in their resetting. This allows the digital watch setting according to time-signals.

The display will automatically **exit from the set mode**, if the buttons are left unused for approximately 1 minute, or you may press and hold the "set" button 2 to exit.

Setting the DER threshold.

To set the DER threshold switch ON the DER indication as described in the clause 2.4.1. Press and fix the "set" button 2 and the LCD will show the preset DER threshold value with a dividing sign "." (point) flashing and the set mode sign and completely filled in linear analogue scale will be displayed (Fig.2.9).

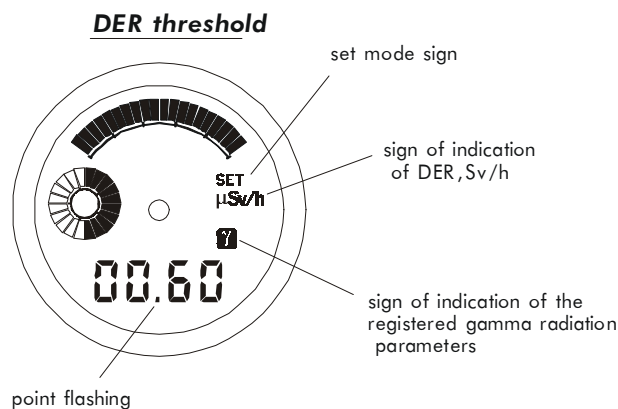

Fig. 2.9

Every short press of the "mode" button 1 will shift the dividing sign (point) or turn it OFF, this allows changing the order of the threshold value.

The next short press of the "set" button 2 will cause flashing of the first two or last two digits of the threshold value. Press and release the "mode" button 1 to correct these digits.

The device will automatically **exit from this mode**, if the buttons are left unused for approximately 1 minute, or you may press and fix the "set" button 1 to exit.

(If the preset threshold is exceeded, an audible signal will sound, the device will enter the DER indication mode if the other value was displayed, and the LCD will show the completely filled in linear analogue scale. The audible signal will sound until the DER value becomes lower than the preset threshold. To stop this signal, press and release the "set" or "mode" button.)

ATTENTION! When replacing the battery of the block of registration of the gamma radiation, the DER threshold will be automatically set at 0.60

$\mu\text{Sv/h}$. The user may set it at his own discretion taking into account the relevant standards or recommendations.

It is not recommended to set the DER threshold lower than 0.35 $\mu\text{Sv/h}$ to avoid the audible signal turning ON due to statistical variations of the indicator readings.

If the upper limit of the DER registration of 4000 $\mu\text{Sv/h}$ is exceeded, an error of registration is not specified.

Setting the DE threshold

To set the DE threshold switch ON the DE indication as described in the clause 2.4.1. Then press and hold the “**set**” button 2, the LCD will indicate the preset DE threshold value with a dividing sign “.” (point) flashing, and the set mode sign and the completely filled in circular analogue scale will be displayed (Fig.2.10).

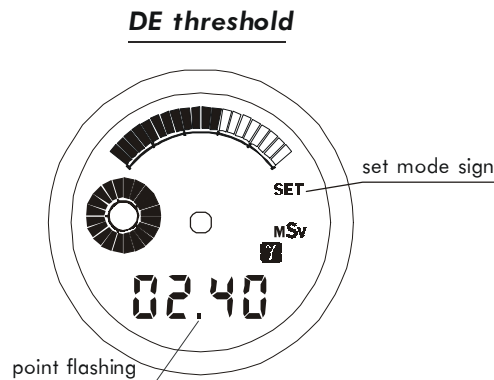

Fig. 2.10

Every short press of the “**mode**” button 1 will shift the dividing sign (point) or turn it OFF, this allows changing the order of the threshold value.

The next short press of the “**set**” button 2 will cause flashing of the first two or last two digits of the threshold value. Press and release the “**mode**” button 1 to correct these digits.

The device will automatically **exit from this mode**, if the buttons are left unused for approximately 1 minute, or you may press and hold the “**set**” button 2 to exit.

(If the preset threshold is exceeded, an audible signal will sound, the device will enter the DE indication mode if the other value was indicated, and the LCD will indicate the completely filled in circular analogue scale. To stop sound signal, press and release the “**set**” or “**mode**” button.)

ATTENTION! When replacing the battery of the block of registration of the gamma radiation, the DER threshold will automatically set at 9999 mSv. The user may set it at his own discretion taking into account the relevant standards or recommendations.

When turning ON the mode of the DE threshold setting, the time of DE accumulation and the DE value are reset. Therefore, to account for the earlier accumulated DE value it is necessary to write down the indicated DE value before setting the new DE threshold value.

2.4.5 Operation in the mode of digital adjustment of the electronic watch accuracy

Enter the Current Time mode as described in the clause 2.4.1 Two short presses of the “**set**” button 2 will enter you to the date and month’s number indication mode. Press and hold the “**set**” button 2 to turn ON the **mode of digital adjustment of the electronic watch accuracy**. The LCD will indicate two flashing digits and the set mode sign. Press and release the “**mode**” button 1 to set the value that is equal to the weekly deviation (in seconds) of the readings from the accurate time.

The device will automatically exit from this mode, if the buttons are left unused for approximately 1 minute, or you can press and hold the “**set**” button 2 to exit.

2.4.6 Mode of indication of partial and critical battery discharge

Measurement of voltage of the battery of the block of gamma radiation registration is carried out automatically after replacing the battery and during operation of the indicator every 24 hours at 00.00.

In the case of partial battery discharge the LCD will display a flashing linear analogue scale (9, Fig.1.2). To make power consumption lower, the audible signals will not sound in any states of the indicator, however it continues to operate in the mode of registration and indication. This shows that **it is necessary to replace the battery of the electronic block of registration! For a continuous account for the DE values, write down the DE value before the battery replacement!**

In the case of critical battery discharge the indicator will discontinue the registration, will not respond to controls and will indicate the DE value existing

at that moment. In this state the device will display the DE value for no less than 24 hours.

2.4.7 The movement of the electronic quartz watch

Operation in the mode of indication of the current time.

The hands that are put in motion by the movement of the electronic quartz watch continuously indicate the current time in hours, minutes and seconds.

To set the correct time, pull the crown out from its normal position until the click, when the second hand is on the digit 12 (the movement will stop). Turn the crown and set the minute and hour hands at the required starting time. To start the movement at time-signals, return the crown to its normal position until the click. The first shift of the second hand will be in a second.

3 MAINTENANCE

3.1 Maintenance of the indicator involves the preventive treatment, battery replacement, and regular operation check up (as described in clauses 2.4.1 – 2.4.4).

3.2 The preventive treatment involves the external examination, removing dust, dirt and decontamination of the indicator case if it is contaminated with radioactive dust.

Decontamination is a treatment of the case with a cloth impregnated with ethyl alcohol.

3.3 To replace the battery it is necessary:

- to turn off and remove the back cover of the indicator;
- to take off the contact plate which covers the battery compartment moving a clip with a screw driver.

Remove step-by-step a battery of the electronic block of registration and a battery of the quartz watch which is located under the first battery.

Insert new batteries observing the polarity: “+” of the battery should be faced towards the indicator cover. Place the contact plate covering the battery compartment, place the cover.

Press and release the “**reset**” button 4 to turn ON the test mode; with this the audible signal will sound, the LCD will display all the segments, then the digital code of the detector, and the indicator will switch to the DER indication mode.

The first DER value of the natural radiation background will be displayed on the LCD in approximately 6 minutes after the necessary statistical data are accumulated and processed.

The current time of the digital and quartz watch is set as described in the clause 2.4.7.

Attention ! To have the batteries replaced It is recommended to take your indicator to a watch shop.

To ensure the water resistance of the indicator it is recommended before placing the cover to clean the sealing ring and its fitting place in the case and to treat them with silicon lubricant. Then screw down the case tight with an appropriate tool.

The recommended battery types are: SR 621 SW (20.5 mAh) for the movement of the electronic quartz watch and CR 2032 (210 mAh) for the electronic block of registration. Otherwise the specifications of the indicator are not guaranteed.

Note that the more frequent and longer use of the backlight and audible signals than indicated in the clause 1.3.13 will significantly shorten the lifetime of the battery of the electronic block.

When the battery of the electronic block is replaced, the information about all the registered values will be lost.

4 TROUBLESHOOTING

Problem	Cause	Solution
1. No indication on LCD. Electroluminescent backlight is not operative when the “ light ” button is pressed	Battery discharge in the electronic registration block Battery is inserted improperly	Replace the battery Insert the battery in proper way. Clean and tight spring contacts
2. Indicator does not respond to button press, LCD indicates incorrect symbols	Microprocessor malfunction	Press the “ reset ” button to restart the microprocessor operation.
Hands of the electronic quartz watch do not move	Battery discharge in the electronic quartz watch	Replace the battery.

5 STORAGE AND SHIPPING

5.1 Indicators in package are to be stored at the air temperature from -15 °C to +50 °C and humidity up to 95 % at temperature of 40 °C.

Indicators without package are to be stored at the air temperature from 10 °C to +35 °C and humidity up to 80 % at temperature of 25 °C.

The storage place should be free of dust, vapours of strong chemicals, aggressive gases and other substances that may cause corrosion.

Indicators are to be stored without batteries if the storage duration is more than 12 months.

5.2 Indicators may be shipped by any kinds of closed transport.

When indicators with batteries are carried by air, the DER threshold should be set at no less than 100 µSv/h. Indicators in package should be placed in hermetic compartments.

When carried by sea, indicators in package should be placed in hermetic plastic bags with silicagel.

5.3 When shipping indicators, the environmental conditions should be within the following limits:

- air temperature from -50 °C to +50 °C,
- air relative humidity up to 100 % at temperature of + 40 °C.

6 WARRANTY

6.1 The manufacturer guarantees that the indicator meets the requirements of Technical Conditions provided that the customer observed the guidelines on its use, shipping and storage described in this manual

6.2 The warranty period of use is 18 months since the date of sale within the warranty period of storage.

6.3 The warranty period of storage is 6 month since the date of acceptance of the device by the officer of the Quality Control Department of the manufacturer.

6.4 Warranty and after-warranty repair are carried out by the manufacturer or institutions that have a permission of the manufacturer.

6.5 Warranty does not cover indicators:

- without the manual ;
- with mechanical damage and if the requirements of use and storage were not satisfied,
- after expiration of the warranty period stated in clause 6.2.

6.6 The warranty period of use is prolonged for a period of warranty repair.

6.7 Warranty does not cover the batteries. The batteries replacement is not considered as the warranty repair.

7 PACKING CERTIFICATE

The wrist gamma indicator PM1208
type 100345122.029-2001
serial number _____

is packed by JV "POLIMASTER" Ltd.
in accordance with requirements described in design specifications.

_____ position _____ signature _____ name

_____ 200 _____.
date

Stamp place

8 ACCEPTANCE CERTIFICATE

8.1 The wrist gamma indicator PM1208 type 100345122.029-2001 serial number _____

is manufactured to meet the requirements of the State Standards and design specifications and is accepted for operation.

Head of Quality Control Department

_____ signature _____ name

“ _____ ”

stamp place

“ _____ ” 200 .

9 WARRANTY CERTIFICATE

The wrist gamma indicator PM1208 type 100345122.029-2001 serial number

is manufactured “ ___ ” _____ .

Manufacturer JV "POLIMASTER" Ltd.
51 Staroborisovsky trakrt, Minsk, 220141,
Republic of Belarus
Tel/Fax: (375 17) 263 81 88, 285-93-48

Date of sale “ ___ ” _____

Seller _____
Signature

Seller stamp _____

The warranty (after warranty) repair is made

“ ___ ” _____

The warranty period is prolonged till

“ ___ ” _____

Manufacturer's officer

signature

Manufacturer's stamp